



# TDR 250 Soil Moisture Meter

## PRODUCT MANUAL

Item # 6250



***Spectrum***<sup>®</sup>  
***Technologies, Inc.***

# GENERAL OVERVIEW

---

Thank you for purchasing the Field Scout™ TDR 250 soil moisture meter. This manual describes the meter's general features and operation.

Soil moisture is a critical, and potentially highly variable, component of the soil environment. Time domain reflectometry is a proven technology for quickly and accurately determining volumetric water content (VWC) in soil. Electrical conductivity (EC) is a function of the moisture and salt in the soil and can be factored out to increase the accuracy of VWC measurements. The meter also measures soil surface temperature. The user can quickly transition between taking VWC readings in standard, high-clay, and sand soils.

The TDR 250's shaft-mounted probe allows the user to take measurements while standing. The meter's built-in data logger eliminates the need to record data manually. Measurements can be saved to a USB flash drive using the built-in USB port.

## Contents

Includes the following components:

- TDR 250 meter
- 4 AA batteries already installed

Note: **TDR rods are sold separately**

---

This manual will familiarize you with the features and operation of your new Field Scout™ TDR 250 Soil Moisture Meter. Please read this manual thoroughly before use

---

# CONTENTS

General Overview	2
Specifications	4
Product Dimensions	5
Meter Care	6
Button Functions	7
Meter Operation	8
Display Screens	9
Setting the Date/Time	12
Maintenance	13
Data Logs	14
VWC Measurements	15
Optional Accessories	16
Appendix 1: Soil Specific Reading Correlation	17
Appendix 2: Troubleshooting	18
Appendix 3: Updating Device Firmware	19
Appendix 4: Calibration	20
Glossary	21
Warranty and Declaration of Conformity	24

# SPECIFICATIONS

---

<b>Measurement Units</b>	Percent volumetric water content (VWC) Period (raw sensor reading)
<b>Resolution, Accuracy and Range</b>	VWC: 0.1% increment $\pm 3.0\%$ @ $< 2$ mS/cm 0% to Saturation ( <i>Saturation is typically around 50% volumetric water</i> )
<b>Connectivity</b>	USB Type A port for USB Flash Drives
<b>Power</b>	4 AA alkaline batteries
<b>Log Capacity</b>	Up to 124,000 measurements
<b>Display</b>	Backlit, high-contrast, graphic LCD
<b>Weight</b>	4.3 lbs. (1.9 kg)
<b>IP Rating</b>	Display: IP53, Probe: IP67
<b>Available Rod Dimensions</b>	Turf 1.5" (3.8cm) Short 3.0" (7.6cm) Medium 4.8" (12.2cm) Long 8.0" (20.32cm) Diameter 0.2" (0.5cm) Spacing 1.2" (3cm)

# PRODUCT DIMENSIONS

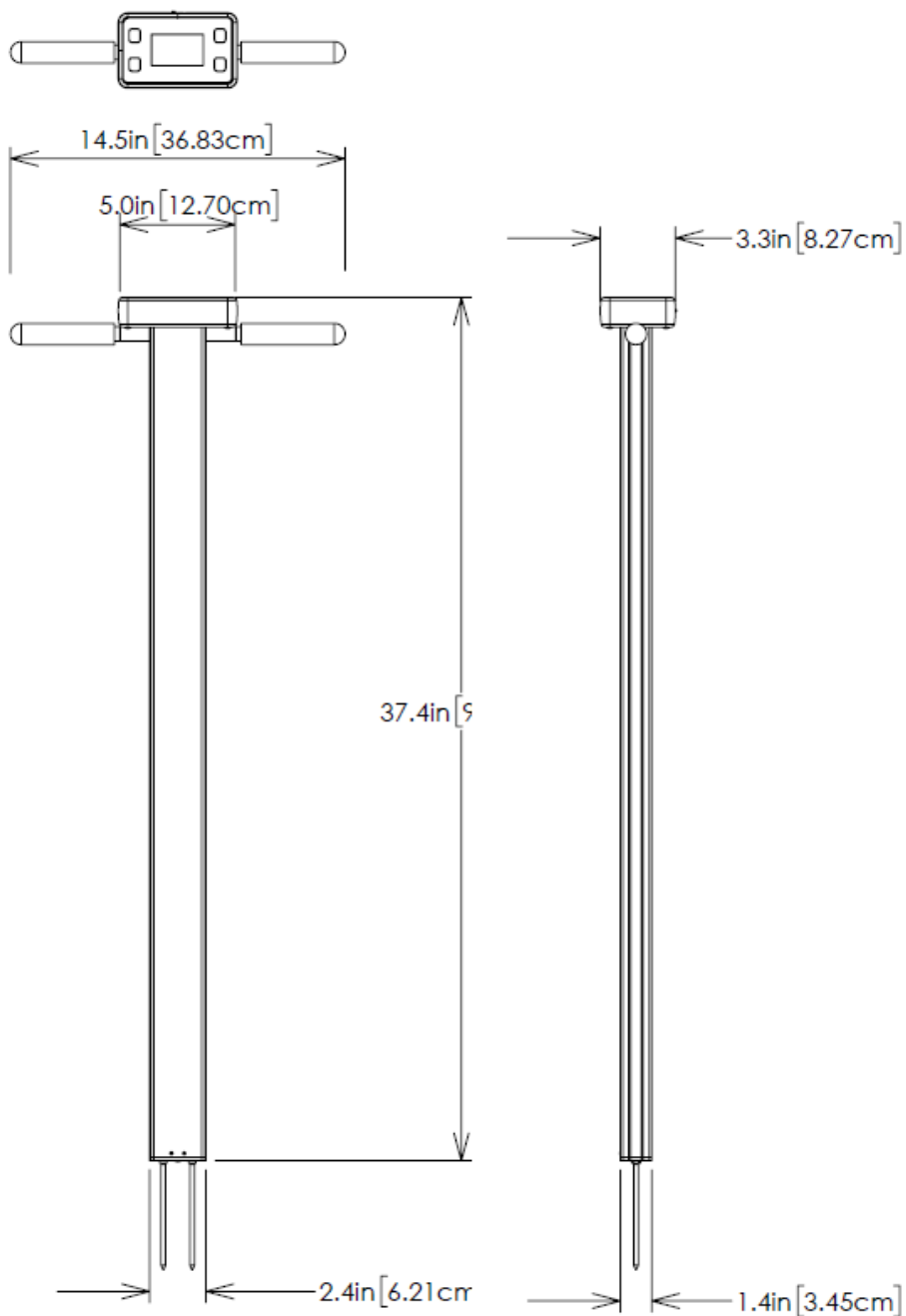

# METER CARE

---

The FieldScout TDR meter will function properly under normal conditions experienced in field use. The sensor block is sealed and will not be damaged by immersion in water. The display is **not** waterproof. The meter should not be used during heavy rainfall or left exposed during irrigation events. If the display does get wet, it should be dried out immediately.

Follow these tips to prolong the life of the device:

- Store in a cool and dry place when not in use.
- Keep the meter and probe rods clean and dry in between uses.
- Remove the batteries if not used for an extended period of time (ie: between seasons).

## Battery life

If the battery level is low or a battery is inserted incorrectly, the low battery icon appears on the screen and the display will power off.

Battery life is affected by the enabled features and frequency of use. If not needed, the backlight can be disabled or set to AUTO mode (page 10) which allows enough time to see new measurements and then will power down the backlight to conserve the battery life.

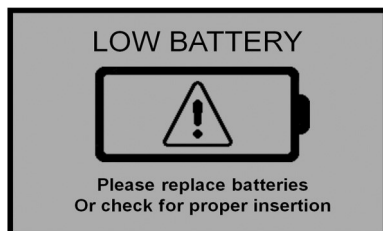

# BUTTON FUNCTIONS

---



## ON/OFF or BACK button

- Press briefly to power on.
- Press and hold to power on and stay on the logo screen.
- Press and hold for 2 seconds to power off.
- Press within a menu to return to prior screen.



## MENU or SELECT button

- Press to enter available menus.
- Press to select or confirm a menu selection.



## DELETE or UP button

- Press to move up within a menu.
- Delete last measurement from the running average, counter, and its entry from the internal data log (see page 14).



## READ or DOWN button

- Press to move down within a menu.
- From Reading screen, press to make a reading.
- Press and hold to reset the average and count.

# METER OPERATION

---

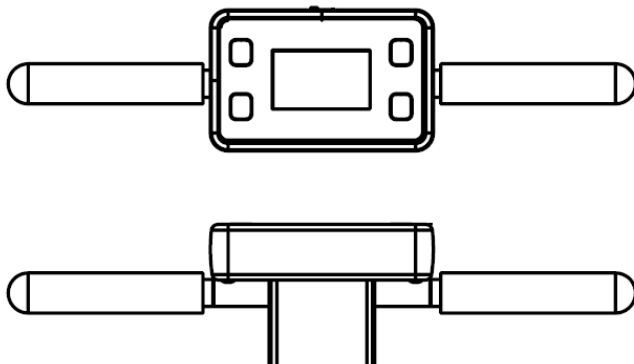

*Figure 1. Handlebars Attached*

## Setting up the meter

1. Slide the lock washers onto the threaded ends of the handle bars.
2. Install the two cushion grip handles and tighten securely.
3. Pull the battery transport tab out of the display unit.
4. Select a set of probe rods and screw them to the bottom of the probe block. Tighten the rods securely.
5. Set the desired user settings in the settings menu. See page 10.

## Taking Readings

1. Grip the TDR handles to the left and right of the display.
2. Push down on the handles maintaining a steady downward pressure to drive the rods into the soil until the sensor base is in contact with the soil surface. Refrain from any back and forth or side to side movement which can introduce air pockets into the soil medium which will alter the reading accuracy.

Caution: Exercise care not to bend or force the rods which could lead to damage.

3. Press the **READ** button and observe the change in results on the top display.



# DISPLAY SCREENS

---

The TDR 250 has 3 main display screens:

- Startup Information (shown on page 7)
- Reading (shown below)
- Settings Menu (see page 10)

## Startup Information screen

Initially displayed after first powered on.

- Displays firmware version information.
- Press and hold **ON/OFF|BACK** button to remain on this screen.

## Reading screen

Measurements from the sensor are displayed on the Reading screen along with rod size used, soil type, and a reading count with running average. VWC=0% readings will be displayed but will not increment the counter or be included in the average.

**Press READ to take readings, update Count and the Average.**



The battery level icon appears in the upper right corner.

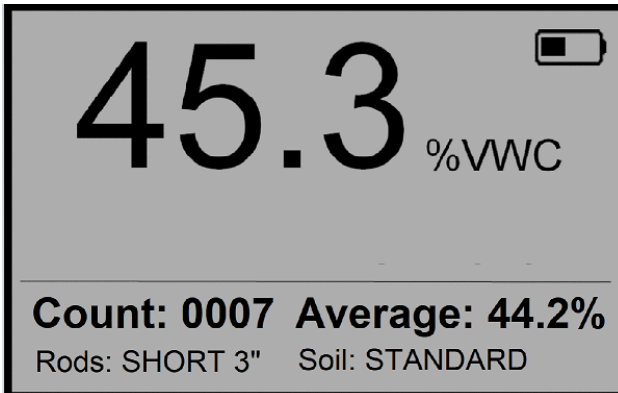

## **Settings Menu screen**

Used for changing device features, setting rod length and working with log files.

Use the arrow buttons to move to the desired option.

The **Select** button toggles through option choices.

**Clear Average\***: Clears the displayed average and count.

Note: Same as pressing and holding the **READ|Down** arrow button

**Rod Length**: Select the Rod length. See page 4 for options.

**Soil Type**: Selects soil type used in measurements:

- Standard: for most soil types.
- Hi-Clay: for soils with higher clay content (> 27%).
- Sand: for sand based fields or turf greens.

**Clear Logs\***: Erases data logs from internal memory.

**Save to USB\***: Transfers data logs to a USB flash drive if attached.

**Backlight**: Sets the LCD backlight: ON, OFF, AUTO. In AUTO mode, the backlight will shut off 5 seconds after a button press

**Sound**: Enable or disable beep for audible feedback.

**Moisture Type**: Selects displayed moisture mode VWC%, Period, or TDR 300.

- VWC%: Volumetric Water Content with EC compensation.
- Period: Raw sensor reading in microseconds (us)
- TDR 300: VWC% without EC compensation

**Auto-Off**: Power off delay: 15, 30, 45, 60 minutes.

**Current Date, Current Time**: Displays or set the current time and date values. See page 12 for details.

**Timezone**: Offset from Greenwich Mean Time. As the offset changes, the Time and Date will update.

**Daylight Savings**: ON or OFF.

**Calibration\***: Overrides factory calibration. See Appendix 4

**Clear User Calibration**: Clears the user applied calibration back to factory settings

**Factory Defaults\***: Resets menu settings and counter to the factory default value.

*\* Pressing Select button for these options brings up an additional screen.*

**About**: Displays general information (Model and serial number, firmware versions for display and sensor).

Defaults:

<b>Rod Length</b>	None	<b>Moisture Type</b>	VWC
<b>Soil Type</b>	Standard	<b>EC Units</b>	mS/cm
<b>Sound</b>	On	<b>Auto-Off</b>	15 minutes
<b>Temperature</b>	Fahrenheit	<b>Time Zone</b>	GMT
<b>Backlight</b>	Disabled		

# SETTING DATE/TIME

---

The Date and Time are displayed in the Settings Menu.

*Note: When the batteries are removed, the date and time are reset.*

## Updating the Date and Time

1. Press the **MENU|SELECT** button to enter the Settings Menu.
2. Press the UP or DOWN arrows to navigate to either the **Current Date** or **Current Time** option.
3. Press the **MENU|SELECT** button to access the Time/Date update screen.
4. Press the **DELETE|UP** button to set the date and time. The current time for the timezone setting will be displayed.
5. Use the UP and DOWN arrows to adjust the highlighted selection.
6. Press the **MENU|SELECT** button to confirm the change and proceed to the next selection.
7. After pressing the **MENU|SELECT** button to set the minutes, the display will return to the Reading screen.

Note: Pressing the **ON/OFF|BACK** button at any point will return to the Settings Menu without making any change.

# MAINTENANCE

---

## **Display and Sensor Separation:**

1. Remove the probe rods from the base.
2. Flip the TDR display over.
3. Remove the 4 screws on the base using a Philips screwdriver.
4. Gently separate the display module from the base plate. Note: The sensor cable connected in the center has limited cable length.

## **Battery Replacement:**

1. Follow the steps above to access the batteries.
2. Install four new AA batteries observing correct polarity by referencing the (+) positive and (-) negative labels.
3. Follow the display installation steps below to reinstall the display.

## **Display Installation:**

1. Re-connect the sensor cable to the 3.5mm connector on the back of the display module if previously removed.
2. Insert the foam spacer back behind the sensor cable. The split end fits around the sensor cable molding.
3. Guide the excess cable back down through the base plate.
4. Align the arrows on the base and display in the same direction. The USB port should face the same side as the serial number label.
5. Tighten the four mounting screws.

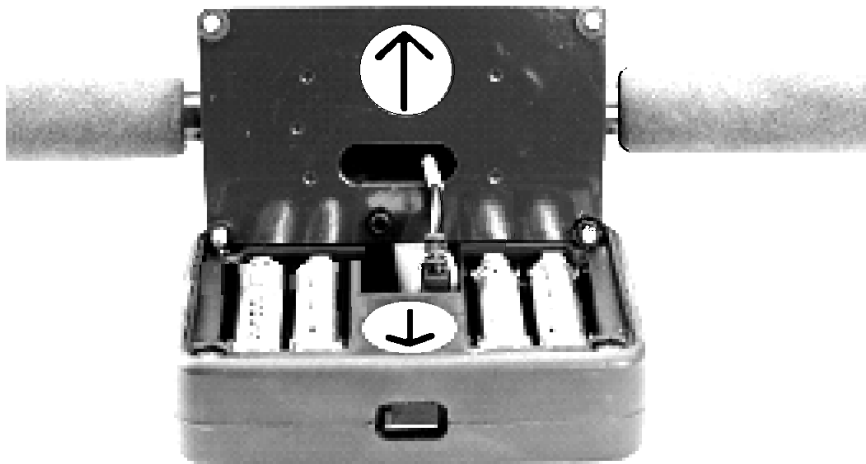

# DATA LOGS

---

## Downloading Data Logs to a USB Flash Drive

1. Connect the flash drive to the meter's USB port.
2. Press the **MENU|SELECT** button to open the Settings Menu.
3. Press the **READ|Down** arrow button to reach the Save to USB option.
4. Press the **MENU|SELECT** button to select the option.

The data will be saved as a comma-separated text file (.csv) with the serial number as the filename. These files can be opened with common text-editing or spreadsheet software. If a previous data file exists on the flash drive with the same filename, it will be over-written. Be sure to save any existing data logs on the flash drive prior to saving a new file.

## Erasing the internal Data log

1. Press the **MENU|SELECT** button to open the Settings Menu.
2. Press the **READ|Down** arrow button to reach the **Clear Logs** option
3. Press the **MENU|SELECT** button to select the option.
4. Press **MENU|SELECT** button again to start the process or the **ON/OFF|BACK** button to return back to the menu.

## Data Collected

The following information is logged with each reading:

### Time, VWC%, Period, Rod Type, Soil Type, VWC Mode

**Time:** based on the GMT offset selected in the **Timezone** option (p. 11)

**VWC%:** Volumetric Water Content based on the Moisture Type setting—EC Compensated or “TDR 300” (without EC compensation)

**Period:** Raw Period result (after any applied user calibration)

**Rod Type:** character is depicted as **L:** Long (8"), **M:** Med (4.8"), **S:** Short (3"), and **T:** Turf (1.5")

**Soil Type:** character depicted as **S:** Standard, **H:** Hi-Clay, and **D:** D sand.

**VWC Mode:** depicted as V for EC compensated or 3 for non-compensated (TDR-300).

# VWC MEASUREMENTS

---

## **Volumetric Water Content (VWC)**

The ratio of the volume of water in a given volume of soil to the total soil volume expressed as a decimal or a percentage. Three soil moisture levels of most importance can be defined as follows:

Saturation: All soil pores are filled with water. The VWC will equal the percent pore space of the soil.

Field Capacity: The condition that exists after a saturated soil is allowed to drain to a point where the pull of gravity is no longer able to remove any additional water.

Permanent Wilting Point: The highest moisture content at which a plant can no longer extract water from the soil.

Additionally, we can define Plant Available Water as the amount of water between Permanent Wilting Point and Field Capacity. One rule of thumb is that irrigation should be initiated when half the Plant Available Water has been depleted.

## **Time Domain Reflectometry (TDR)**

The speed of an electromagnetic wave along a waveguide in soil is dependent on the bulk dielectric permittivity ( $\epsilon$ ) of the soil matrix. The fact that water ( $\epsilon = 80$ ) has a much greater dielectric constant than air ( $\epsilon = 1$ ) or soil solids ( $\epsilon = 3-7$ ) is exploited to determine the VWC of the soil. The VWC measured by TDR is an average over the length of the waveguide.

The sampling volume is an elliptical cylinder that extends approximately 3 cm out from the rods. The high frequency signal information is then converted to volumetric water content. High amounts of clay or high electrical conductivity ( $EC > 2$  mS/cm) will attenuate the high-frequency signal and affect the reading displayed by the meter. Very high organic matter content will similarly affect the VWC reading.

# OPTIONAL ACCESSORIES

---

There are two optional items that can be used to expand the capabilities of the TDR. Visit [www.specmeters.com](http://www.specmeters.com) for more information and installation instructions.

## **TDR Spacer (item 6435SP)**

- Placed on the end of the sensor block to aide in identification of how fast and firm the turf greens are. The spacer has two orientations allowing it to work for either desired depth.
- Requires 3.8 cm (1.5") turf rods.
- For use with firmware version 1.02 or higher
- Allows for the measurement of 1.3cm (0.5") or 2.5cm (1.0") soil depths.

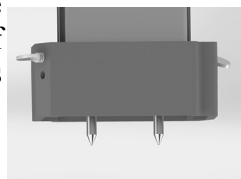

## **Pilot Hole Maker (item 6430PH)**

If the ground is especially hard or compact, you can use a Pilot Hole maker to make 3" holes to aid in starting the insertion of the probe rods.

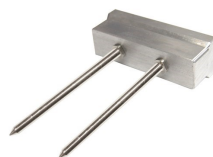



# APPENDIX 1: SOIL-SPECIFIC READING CORRELATION

---

To improve accuracy, correlate TDR period readings with a soil-specific sample set.

VWC data can be correlated by measuring the weight of a known volume of saturated soil as it is gradually dried, by gradually wetting a known volume soil with measured increments of water, or by using a neutron probe. In most cases, gravimetric sampling is performed. This procedure is briefly described below.

1. Establish a number of field sites to sample.
2. Wet each site with varying amounts of water.
3. Obtain FieldScout TDR period reading at each sample site.
4. Extract a known volume of soil at each sample site. Ideally, an undisturbed soil core. Reduce evaporation - store samples in a sealed plastic container.
5. Weigh the wet soil samples.
6. Dry the samples (105°C for 48 hours) and weigh again.
7. Plot sample measurements against FieldScout TDR readings. Regression analysis is used to develop a formula to correlate TDR readings to the sample data.

## **Volumetric water content calculations:**

$$\text{VWC} = 100 * (M_{\text{wet}} - M_{\text{dry}}) / (\rho_w * V_{\text{tot}})$$

## **Gravimetric water content calculations:**

$$\text{VWC} = \text{GWC} * (\rho_b / \rho_w)$$

$$\text{GWC} = 100 * (M_{\text{wet}} - M_{\text{dry}}) / M_{\text{dry}}$$

$$\rho_b = M_{\text{dry}} / V_{\text{tot}}$$

Where:

$M_{\text{wet}}, M_{\text{dry}}$  = mass (g) of wet and dry soil respectively

$V_{\text{tot}}$  = total soil volume (ml)

$\rho_w$  = density of water (1g/ml)

# APPENDIX 2

## TROUBLESHOOTING

---

### Sensor Function Verification:

Test readings can be taken in three standard environments; air, distilled water, and sand saturated with distilled water. It is important that any troubleshooting be done with distilled water instead of municipal well or tap water. Test readings are made in a container of distilled water or saturated sand. The container should have a diameter of at least 3 inches (7.5cm) and should be tall enough so the rods can be completely immersed or inserted.

Readings should be taken with the **Soil Type** set to Standard and the correct **Rod Length** selected. The meter should read VWC=0% in air. In saturated sand, it should read between 35% and 45%. The table below shows the approximate ranges of volumetric water content that are expected for the different rod lengths in distilled water.

Rod Length	Water
8 inches (20 cm)	60 - 65%
4.8 inches (12 cm)	70 - 75%
3 inches (7.5 cm)	75 - 80%
1.5 inches (3.8 cm)	65 - 70%

Note: The meter does not read 100% in water as the reading is run through soil equations created to be most accurate in the volumetric water contents typically found in the selected soil type.

### Unable to save data or load firmware from USB flash drive:

Confirm the drive is not full. Verify the drive has FAT or FAT32 format. Firmware should be in the root directory; outside of any folders.

### "No Sensor" appears on the display:

The sensor cable may be dirty or unplugged. Clean the cable connection. Check the cable connection to the display. Confirm that the probe block is securely plugged into the display.

# APPENDIX 3: UPDATING DEVICE FIRMWARE

---

Firmware updates may be made available to add or improve the product features. The firmware can be updated using a USB flash drive. Firmware update files can be found on the Spectrum website.

1. Copy the latest firmware update from your PC onto the root directory of the flash drive. The file will not be seen by the meter if it is renamed or stored within a folder on the drive.
2. Power off the meter.
3. Remove the protective cap from the meter's USB port.
4. Insert the flash drive into the meter's USB port.
5. While pressing the **DELETE|Up arrow** button, press and release the **ON/OFF|BACK** button. The meter will beep briefly and the screen should stay blank.
6. Release the buttons. Note: The display screen will remain blank during the update process. The meter will beep a second time once the process has completed and then reboot to the logo screen. The new firmware will now be displayed below the Spectrum logo.
7. The display will alert the user if further updates are to be made and show a message when completed.
8. Remove the flash drive and replace the USB cover.

## APPENDIX 4: CALIBRATION

---

The FieldScout TDR is fully calibrated at the factory. Further calibration is not required nor recommended. The meter has internal calibrations for standard, sand, and high-clay soil types which will work for many soils. Each meter will have a small difference in how it responds to identical soil conditions. This can be due to air being introduced while measuring, bent probes, loose probes, sensor drift or component tolerances. The meter allows for adjustments to the calibration to account for these differences. Should the user prefer to perform the calibration; the following are required:

1. A clean glass or plastic container. The container must be at least 10cm (4") wide and at least 5.08cm (2") longer than the length of the TDR rods.
2. A sufficient volume of unused distilled or de-ionized water to fill the above container. **Note: Tap water cannot be substituted.**

Procedure:

1. Pour all of the distilled/deionized water into the container. The water level must be deeper than the rods currently installed. Note: The water and container must be free of minerals and salts to calibrate properly.
2. From the Settings Menu (page 10), set the rod length to the correct length of the rods currently installed.
3. From the Settings Menu, choose the Calibration option.
4. Press the **Select** button to initiate the calibration process. Follow the display messages.
5. While keeping objects and personnel clear from the area; raise the meter so the rods are in the air. Press the **MENU|SELECT** button and wait until the meter indicates it is ready.
6. Immerse the rods completely in the deionized or distilled water till the sensor base is in contact with the liquid. Keep the sensor base and rods centered in the container.
7. Press the **MENU|SELECT** button and wait until the meter indicates it is ready.

The meter will then show that the calibration is complete for that specific rod length. If more than one rod size is being used, a calibration operation must be done for each rod length used.

# GLOSSARY

---

**EC:** Electrical Conductivity. A measure of how well the soil solution conducts electricity. The EC is influenced by the amount of salt and water in the soil.

**TDR:** Time Domain Reflectometry. A technique for measuring soil moisture content that uses the fact that water has a much higher dielectric permittivity than air, soil minerals, and organic matter.

**VWC:** Volumetric Water Content. The percent of the soil volume that is filled with water. At saturation, the VWC will equal the soil porosity.



### **Warranty**

This product is warranted to be free from defects in material or workmanship for two years from the date of purchase. During the warranty period Spectrum will, at its option, either repair or replace products that prove to be defective. This warranty does not cover damage due to improper installation or use, lightning, negligence, accident, or unauthorized modifications, or to incidental or consequential damages beyond the Spectrum product. Before returning a failed unit, you must obtain a Returned Materials Authorization (RMA) from Spectrum. Spectrum is not responsible for any package that is returned without a valid RMA number or for the loss of the package by any shipping company.



#### DECLARATION OF CONFORMITY

Spectrum Technologies, Inc.  
3600 Thayer Ct.  
Aurora, IL 60504 USA

Model Numbers: 6250  
Description: Portable Soil Moisture\Conductivity Probe  
Type: Electrical Equipment for Measurement, Control, and Laboratory Use  
Directive: 2004/30/EU  
Standards: EN 61326-2:2012  
EN 61000-6-1:2007  
EN 61000-6-3:2007+A1:2010  
ICES-003:2016; ITE Emissions for Canada (ANSI C63.4:2014)  
FCC Part 15:2016: Emissions for Unintentional Radiators for  
USA (ANSI C63.4:2014)  
EN 55032:2015

Robert Benesh, Electronics Engineer

Pending

# ***Spectrum<sup>®</sup>*** ***Technologies, Inc.***

**3600 Thayer Ct.  
Aurora IL 60504  
(800) 248-8873 or (815) 436-4440  
Fax (815) 436-4460  
E-Mail: [info@specmeters.com](mailto:info@specmeters.com)  
[www.specmeters.com](http://www.specmeters.com)**