

P² PICKER

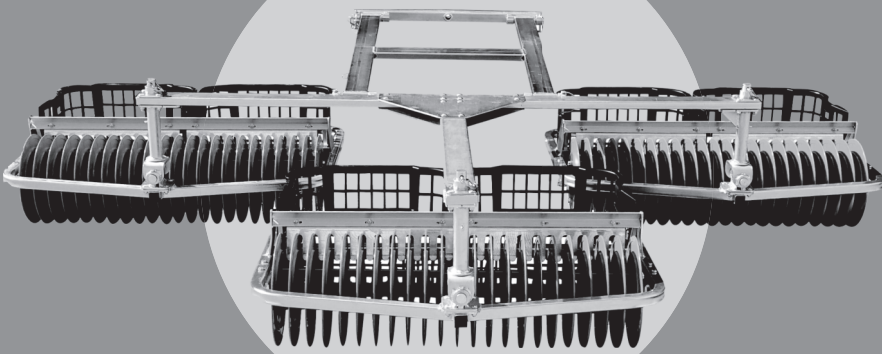

P² GOLF PRODUCTS

Engineered for Productivity & Performance



Operational & Repair Manual

Models:

P2P3S (3 Gang)

P2PP3S (3 Gang)



TABLE OF CONTENTS

WELCOME	2
WARRANTY	2
UNPACKING	3
ASSEMBLY	4
OPERATION	5
MAINTENANCE	6
DISC REPLACEMENT PROCEDURE	7
TROUBLESHOOTING	8
SCHEMATIC	9
PARTS LIST	10

WELCOME

THANK YOU for choosing P² Golf! We warmly welcome you as the newest member in our driving range equipment family.

With P² Golf you can be assured that we share your same goals. We want all your range equipment to work for you, so we work extra hard to provide the best, highest quality, efficient product delivered promptly every time.

Our complete line of range equipment is made by us in our very own manufacturing facility using only high grade, heavy gauge galvanized steel. We are confident that our range equipment will outperform anything on the market today.

Our confidence is a result of being **PREPARED, PROACTIVE & POSITIVE.** This comes from who we are at our core - good people with high integrity and character. These values have always been the pillars to our success since 1950 and it's what we promise to deliver to you, our customer every time.

WARRANTY

ALL P² PRODUCTS ARE WARRANTED TO BE FREE FROM DEFECTS IN MATERIALS AND WORKMANSHIP **ONE YEAR FROM DATE OF PURCHASE** AND SUBJECT TO LIMITATIONS & GUIDELINES LIST BELOW:

THE WARRANTY DOES NOT COVER NORMAL WEAR AND TEAR, ABUSE, OVERLOADING ALTERATIONS, IMPROPER FLUIDS OR USE IN A MANNER THAT EQUIPMENT WAS NOT INTENDED.

THE WARRANTY DOES NOT COVER MALFUNCTION OR DAMAGE DUE TO OPERATION NOT IN COMPLIANCE WITH THE OPERATION INSTRUCTIONS IN THIS MANUAL. WARRANTY DOES NOT COVER NEGLIGENCE DUE TO NOT PERFORMING PERIODIC INSPECTIONS & MAINTENANCE. THESE PROCEDURES ARE NECESSARY TO DISCOVER ANY INDICATION OF MALFUNCTION OR FAILURE AND MAINTAIN PEAK PERFORMANCE. PLEASE REFER TO MAINTENANCE SECTION OF THIS MANUAL FOR GUIDELINES ON INSPECTION INTERVALS & PROCEDURES.

IF YOU BELIEVE A PRODUCT IS DEFECTIVE PLEASE CONTACT US IMMEDIATELY SO THE APPROPRIATE ACTION CAN BE TAKEN.

UNPACKING & INSPECTION

All P² PICKERS are packed complete with all components and parts. Before assembly check that all parts are accounted for. Contact us at 1300 138 804 immediately if anything is missing.

P² PICKER P2P3S (3 Section) contains:

- 3 – PICKER SECTIONS COMPLETE WITH INSTALLED DISC SETS
- 1 – CENTER FRAME COMPLETE WITH HARDWARE
- 1 – PUSH FRAME WITH ATTACHED PUSH BAR COMPLETE
- 6 – PLASTIC PICKER BASKETS

P² PICKER P2P5S (5 Section) contains:

- 5 – PICKER SECTIONS COMPLETE WITH INSTALLED DISC SETS
- 1 – CENTER FRAME COMPLETE WITH HARDWARE
- 1 – PUSH FRAME WITH ATTACHED PUSH BAR COMPLETE
- 10 – PLASTIC PICKER BASKETS
- 2 – OUTRIGGER ARMS

P² PICKER PLUS P2PP3S (3 Section) contains:

- 3 – PICKER SECTIONS COMPLETE WITH INSTALLED DISC SETS
- 1 – CENTER FRAME COMPLETE WITH HARDWARE
- 1 – PUSH FRAME WITH ATTACHED PUSH BAR COMPLETE
- 9 – PLASTIC PICKER BASKETS

P² PICKER PLUS P2PP5S (5 Section) contains

- 5 – PICKER SECTIONS COMPLETE WITH INSTALLED DISC SETS
- 1 – CENTER FRAME COMPLETE WITH HARDWARE
- 1 – PUSH FRAME WITH ATTACHED PUSH BAR COMPLETE
- 15 – PLASTIC PICKER BASKETS
- 2 – OUTRIGGER ARMS

At the time of unpacking please examine the shipment for loss or damage. Inspect all components for visible damage. If any damage or loss is discovered, take pictures and report it to us at 1300 138 804 so we can take the appropriate action

ASSEMBLY

All P² PICKERS are packed complete with all components and parts. Before assembly check that all parts are accounted for. Contact us at 1300 138 804 immediately if anything is missing.

Tools needed: ½" Wrench or Socket

1. Start with CENTER FRAME - remove the 8 bolts at rear of center triangle.
2. Fold out LEFT & RIGHT arms.
3. Replace bolts and tighten.

Mounting the PUSH FRAME (H-Bar):

1. LINE UP to back of CENTER FRAME and INSERT
2. Insert PUSH BAR PINS
3. Secure with LYNCH PINS

Installing PICKER SECTIONS:

1. Position SECTIONS at END of each ARM
2. Position U-JOINT in UPRIGHT position
3. SLIDE arm assembly onto U-JOINT and secure with PIN. REPEAT with remaining gangs.

Your P² Picker is now completely assembled and ready to connect to drive vehicle.

Attaching to VEHICLE:

1. PULL vehicle UP to within a few inches from PUSH FRAME.
2. INSERT PIN on CART BRACKET through hole on MOUNT BAR/PUSH FRAME ASSEMBLY.
3. SECURE with LYNCH PIN.

Your P² Picker is now completely assembled and ready for use.

OPERATION & USE

Each range is unique so picking frequency and patterns will be specific and different for every range. For increased operational reliability and service life, we recommend the following general guidelines for the best use:

Only use P² Picker for picking up golf balls on driving range grass, sod or turf pushed by a limited power vehicle such as golf cart. Avoid abrasive & rugged terrains such as asphalt, concrete, stone, gravel, parking lots or cart paths.

Before use, evaluate weather and ground conditions. Driving over standing water and mud can cause you to get stuck. If the ground is damp, remove accumulated grass clippings that buildup between the rotating discs and the baskets. Doing so will keep the discs rotating properly.

- Always drive at a slow pace. Try to maintain speeds of 8 mph or less.
- Use straight overlapping pattern similar to mowing grass.
- Make sure to give yourself plenty of turning radius and avoid sharp turns.
- Avoid driving up steep slopes for long distances.

PROHIBITED USE:

Never use picker for long distance travel or for transporting persons or anything other than baskets filled with picked golf balls.

Do not overload picker with more balls than capacity limits:

P² Picker 3 Section: 1,800 Balls

P² Picker Plus 3 Section: 2,700 Balls

P² Picker 5 Section: 3,000 Balls

P² Picker Plus 5 Section: 4,500 Balls

Modifying with components or parts not intended for the P² Picker. Always use P² replacement parts that are intended for P² Pickers and approved by us.

MAINTENANCE

P² Pickers are designed to provide many years of reliable operation. However, it is recommend to follow a regular inspection and maintenance schedule to discover any malfunctions early to prevent breakdowns. This will ensure optimum ball picking and a long service life.

Below is a recommended maintenance schedule:

DAILY:

Check for physical damage and tighten loose hardware.

Check discs and ball comb placement. Fingers should NOT be touching discs. If so, loosen securing bolts, adjust and retighten.

Remove objects that became lodged between discs during picking runs. For example, broken golf, balls, pine cones, oak balls, rocks, etc.

MONTHLY:

Hose down baskets and discs to remove accumulated dirt or fertilizer that can cause rust and corrosion.

Check for broken or loose discs. Broken discs must be replaced. Call us at 1300 138 804 or visit us on line to order replacement discs then follow Disc Replacement Procedure on page 8. If discs can be moved side-to-side this indicates loose discs and they must be tighten. To tighten:

Lubricate all hinge points and zerk locations. Zerk locations are shown below:

SEASONAL STORAGE:

Thoroughly wash, clean and dry picker. Lubricate all nuts and bolts and replace any that are rusted or damaged.

Store undercover or sheltered to protect from extreme weather & climate conditions.

DISC REPLACEMENT PROCEDURE

P² Pickers are designed for continuous use and engineered for durability. However, parts such as discs, baskets and other components are subject to wear and may eventually require replacement.

All P² PICKER DISCS and REPLACEMENT PARTS are in stock and available on our online store at www.countryclub.com.au or contact us at 1300 138 804. In an emergency most parts can be shipped Next Day Delivery.

Tools needed: 1/2" Wrench and 9/16" Socket

1. Start with AXLE BRACKETS - using wrench remove the nuts & bolts from each end of axle bracket.
2. PULL drum section out of DRUM FRAME.
3. REMOVE nuts from each of 4 RODS on one end of drum section with socket.
4. PULL RODS out only far enough to remove the disc(s) that need replacing.
5. THREAD new discs into place as needed.
6. REPLACE all DISCS that were REMOVED.
7. INSTALL and finger tighten nuts on RODS.
8. USING A GOLF BALL as a guide, insert golf ball in the space between each disc to determine a snug fit and ball doesn't slide down. If sliding occurs, tighten nuts on tie rod until you have reached desired space in each disc section.
9. SLIDE drum section back in DRUM FRAME aligning ball comb fingers between each disc. Re-install axel brackets with nuts and bolts and tighten.

NOTE FOR PICKER PLUS:

RE-INSTALL Half Drums with Nylock Nuts FACING CENTER. Use appropriate slip discs and galvanized spacers in between drum split sections (see diagram).

TROUBLESHOOTING

The P² Picker is one of the most reliable and effective models of ball picker currently on the market. However, occasionally there may be a malfunction. These are caused for different reasons. Below is a list of the most common and our recommended solutions:

PROBLEM	REASON	SOLUTION
Not picking up balls	Driving Too Fast Object lodged between discs Tie Rods are loose	Slow down to 8mph or below Check & remove objects between picking runs Tighten 3/8" nuts
Broken discs	Hitting sprinklers Driving too fast into turns Being driven on abrasive terrain	Slow down to 8mph or below Slow down to 8mph or below Only drive on sod, grass or artificial turf
Heavy Disc Wear	Ball Comb not aligned Being driven on abrasive terrain	Check the spacing of ball comb fingers daily. Only drive on sod, grass or artificial turf
Chewed up balls	Object lodged between discs Ball Comb bent too far forward	Check & remove objects between each picking run Adjust ball comb back allowing ball to pass into basket
Seizing	Not following a proper Maintenance schedule	Lubricate all hinge points & grease zerk fittings regularly. See page 8 for recommended maintenance schedule.
Drum Sections Rattles	Drum Sections are loose	Secure by realigning axle brackets

P² PICKER OPERATIONAL & REPAIR MANUAL

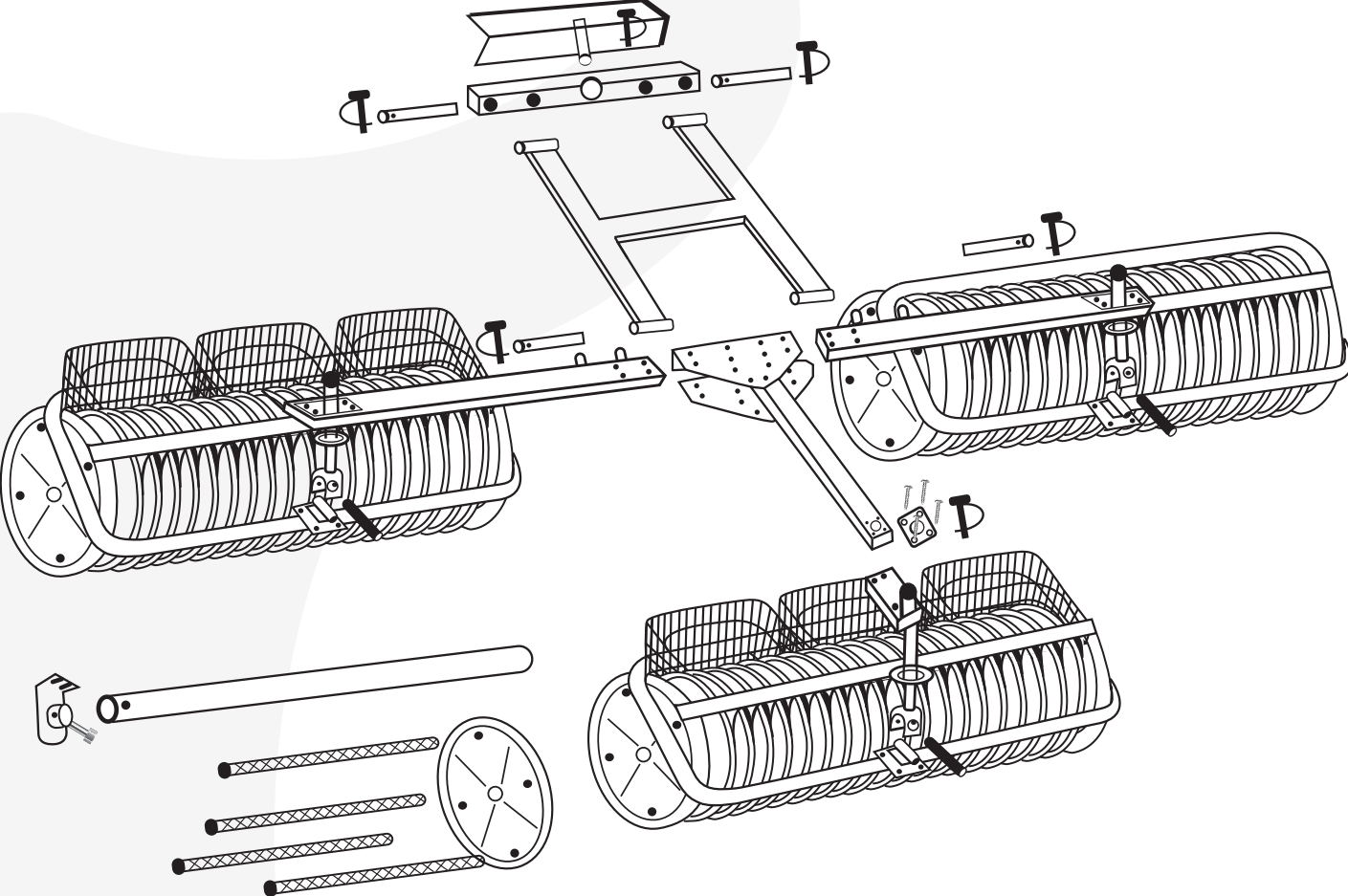

P² PICKER OPERATIONAL & REPAIR MANUAL

REPLACEMENT PART SHEET FOR P2P3S/P2P5S PICKER

ITEM	NUMBER	DESCRIPTION
1	P2P09	LYNCH PIN
2	P2P07	¾" PUSH BAR PIN
3	P2P28	REPLACEMENT BASKET
4	P2P03	CENTER FRAME L/R ARM
5	P2P24	U-JOINT BARREL & RETAINING PLATE
6	P2P12	AXLE BRACKET
8	P2P11	PICKER AXLE
9	P2P13	THREADED ROD w/ NUT
10	P2P02	CENTER FRAME CENTER
11	P2P17	23 REPLACEMENT DISC SET COMPLETE
12	P2P15	DISC
12	P2P16	END DISC
13	P2P19	BASKET BAR
14	P2P04	CENTER FRAME GUSSET SET
15	P2P26	NOSE BEARING PIN
16	P2P25	NOSE BEARING
17	P2P23	U-JOINT
18	P2P14	BALL COMB
19	P2P06	PUSH FRAME
20	P2P08	PUSH BAR



P² products are warranted to be free of defects in materials and workmanship under normal use and subject to the guidelines and limitations listed. This warranty does not cover: normal wear & tear, abuse, overloading, alterations, improper fluid or use in a manner for which they are not intended. If you believe a product is defective, the product must be delivered, or shipped to Country Club International for evaluation and repair.



6 Gateway Drive, Carrum Downs, Victoria, 3201
1300 138 804



**P2 GOLF
PRODUCTS**

Engineered for Productivity & Performance